

Warton Stock Car Club

Junior Rookie Rules

This formula is designed to encourage new young drivers to Warton Stock Car Club, to enjoy the atmosphere and thrills of driving on an oval, without the substantial financial investment.

The object of the racing is to complete the specified number of laps in the shortest time. You may push a car from behind, or spin a car to the infield but there is no following in (you must not be on the back or side of a car as it hits the fence whether from the rear, front or side as this will be deemed forcible fencing and carry penalties or a ban which could be for life). **Deliberate hitting of stationary cars is not permitted.**

Driver's must be between the ages of 11 and 15 – the earliest date upon which someone can race is on their 11th birthday. The latest date is the day before their 16th birthday. All licence applications will be reviewed by the club and it must be understood that applications may be refused at the club's discretion. Falsifying documents or providing misleading information about age in order to get round the rules carries a lengthy ban from all formulas. All drivers have to complete a competence assessment prior to racing.

All new Drivers to the class must take a competency test both practical and written before they will be allowed to race. ALL drivers regardless of age or experience will need to take one. Failure to pass the test means you will not be allowed to take part in the meeting.

Day licences are permitted for one race meeting ONLY. Once you have had a day licence you must purchase a full membership if you wish to race again. To run on a day licence you will need to hire a Racer receiver.

There is a list of eligible cars which is below, if you have a car not listed below please contact a scrutineer to check if it is eligible. The car must be a right - hand 2 wheel drive saloon, hatchback or estate car with a steel body with an engine size not exceeding 1300cc, with either carburettors or Multi Point Injection or Diesel.

Engine limit – 1300cc – some models listed below were not made under 1300cc in which case an engine transplant under 1300cc must be used.

Austin - A30 / A35 / A40 (Farina only - NOT Somerset or Cambridge) / 1100 / 1300 / Allegro / Metro
Chevrolet – Matiz
Citroen - 2CV / Dyane / AX / Saxo / Visa / C1
Daewoo - Matiz
Daihatsu – Charade / Move
Datsun - 100A (Cherry)
Fiat - Panda / Punto / Uno / 126 / 127 / Cinquecento / Tipo / Seicento
Ford - Fiesta / KA / Popular 100E / Anglia
Hillman - Imp
Honda - Civic (1st generation 1972 - 1979 only) / Logo
Hyundai – i10 / Amica
Kia – Pride / Picanto
Lada – Samara
Lancia - Fulvia
Mini (Not BMW Mini)
Mazda – 121 / 323 (3rd generation 1977 - 1980 and 4th generation 1980 - 1984 hatchbacks only – not booted versions or estates) / Demio
Morris - 1100 / 1300 / Minor
Nissan – Micra (K10-K12) / Pixo
Perodua - Kenari
Peugeot - 104 / 106 / 107 / 205 / 206
Proton – Satria / Compact

Renault - 4 / 5 / 6 / 10 / Clio / Modus / Twingo
Riley - Elf
Rover - 100 (Metro shape - not p4!)
Seat – Ibiza (mk.1 1984 - 1993 & mk.2 1993 - 2002) / Arosa
Skoda – Favorit (saloon only – NOT estate)
Smart Car
Subaru - Vivio
Suzuki – Swift / Wagon R / Baleno (3 door hatchback ONLY, NOT booted version or estate)
Talbot - Samba
Toyota – Starlet / Aygo / Yaris
Vauxhall - Nova / Corsa (excluding 'D') / HA Viva / Chevette
Volkswagen - Polo / Beetle / Fox / Lupo
Wolseley - Hornet
Yugo

INITIAL PREPARATIONS

- Remove all exterior mouldings, screen glass, lamps and handles.
- Remove all **airbags and charges (if fitted)**, interior trim, the dash & passenger seating.
- Remove the fuel tank, spare wheel carrier & tow bar if fitted.
- **Remove rear spoilers and side skirts even if factory fitted.**
- Remove all obsolete wiring and interior debris from the car.
- It is compulsory to pad steering columns, B pillar and roll cage with high density foam – it is NOT permissible to use non-high density padding such as clothing, towels etc.
- For Safety reasons, it is compulsory to fully tape over the steering wheel to avoid possible wrist injury. This can be with tape or a substantial perspex disc.

DRIVERS SEAT WITH HEAD RESTRAINT

You must have a Driving Seat with a head restraint and this may be of a competition type. The seat should occupy its original position where possible and be suitably supported at shoulder height and on both of the sides and back, with a suitable framework or seat stiffeners.

Seats with airbags must be replaced with a standard seat.

SAFETY HARNESS

The lap belt/straps and crotch straps should not pass over the sides of the seat, but through it, in order to wrap and hold the pelvic region over the greatest possible surface. A minimum of a four point buckle fixing must be used with a minimum of 3 floor fixings. A secure part of the floor or cage (including the seat bar), are recommended anchor points. All seatbelt connection points must be visible and no belts pass through any firewall.

The lap belt crossing should be below the anterior-superior iliac spines (bony part of the hip). Under no circumstances should it be worn over the region of the abdomen.

Lap belt/straps must terminate vertically downwards, and not forwards or rearwards of the hip joint.

Lap straps should terminate symmetrically about the wearer on either side of the seat, about 20" (500mm) apart. The distance between the seating surface and the anchorage point should be kept to a minimum to prevent submarining. The location of the crotch strap mounting should be to the rear of the driver.

All belts must connect to the quick release buckle. The abdominal strap fixing point must be on the chassis, roll cage, or floor (for vehicles with no chassis), either side of the driver.

The shoulder straps must be supported at shoulder height. NASCAR type buckles must be fitted with lever on the **right** side of the driver. It is advisable to fit a secondary means of detent to prevent overall sleeves accidentally

unhooking the buckle during racing. A small section of tube grip **elasticated** bandage, slid over the hooked buckle, serves the purpose.

Special attention must be paid to the condition of seat belt fixings once fitted. Information is available, from your Promotion, on the correct procedure to follow when fitting seat belts. *Remember - your life depends on them, and belts, once involved in a severe accident, should be discarded and replaced.*

Over the years, we have had many unnecessary injuries due to badly fitted seats. They frequently occur in Non-contact Formulas, when perhaps a driver believes it is more unlikely that he will be involved in a serious crash, and he also believes that, if he is involved in a collision, the impact on his car will be from the front. However, this is often not the case. It is therefore, imperative that you ensure your seat is really well supported, especially where the shoulder straps go through. You must also ensure that your seat cannot move sideways

The safety of your seat will be judged by the Scrutineers and you will only be permitted to race when they are satisfied that you will be as safe as possible in any event.

WINDOW NET

A race manufacture window net in the driver's door window is **compulsory**. **This must be fitted with a quick release mechanism.**

VIOLATIONS

- When referring to the engine, gearbox, final drive, mechanical or construction Rules & Regulations, the principle will always be: *Unless permission is specifically granted to make modifications (or any variation) nothing may be done to alter or change the Standard Parts in any way.*
- It is the responsibility of the Driver to prove to the Promotion that the part is legal, by way of written proof of where the part originated. This must be undertaken within 7 days, otherwise the item in question will be deemed illegal, resulting in immediate suspension from racing and referral for disciplinary action. **Unless the rules say you can do it, you cannot do it!**
- Presentation of a Vehicle for Scrutineering is a declaration by the entrant that the vehicle is eligible for that event.
- Car engines and fuel will be checked on a random basis. Violations or refusal to allow an engine check will result in an immediate suspension of all racing facilities.
- All Car and Engine Specifications will be taken from either the manufacturers Technical Specifications or the Technical Service Data books as published by Glass's Guide.
- **Should a discrepancy occur between the Specifications then the Promotion will exercise it's judgement, and that decision will be final.**
- Clarification on any one item may be sought from the Promoter.
- Each driver is permitted one car per meeting and each car is permitted one driver per meeting.

GENERAL RULES OF RACING

- Drivers apprehensive about contact can display on the rear of the car a black or white X, to signify to other drivers that they must not make contact with your car during racing.
- The Clerk of the Course has at his discretion the right to remove the cross from you, when he thinks you are confident to race with the others.
- You must line up in reverse points order, with the superstar/reds at the rear of the grid, with blue, yellow and white in front.
- Race winners will start at the back of their respective roof grade for the following race.

ROLL BAR

- Roll cages may be adjustable (height and width), however the use of screw adjusters i.e. acrow style are not permitted.

- On adjustable roll cages the bolt(s) governing the height of the roll bar must pass through the roll bar socket and the extension, and spacer between the roof and roll bar may not exceed 50mm (2"). Also where the socket is there must be two bolts each side of the socket
- The roll cage must be fitted upright or dog-legged, but not leaning back or forward.
- **It is compulsory to pad roll cages, including the B pillar and steering columns with foam type padding.**

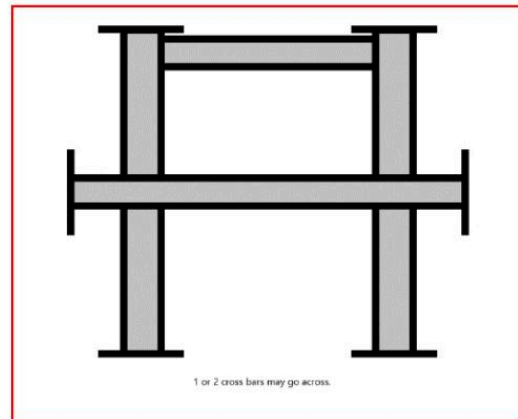
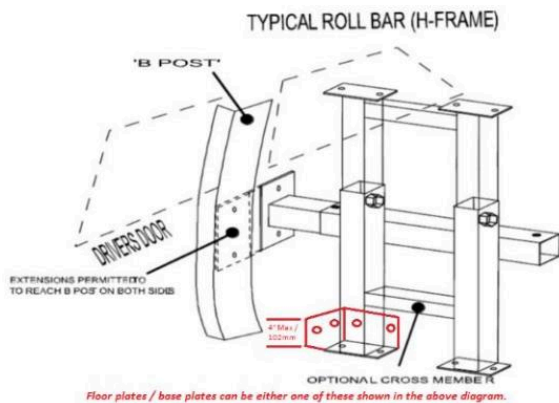

These two diagrams are a guideline to how the frame should be constructed but gusseting or triangulation is accepted.

- The hoop must be one piece or two uprights and one top bar of a welded construction. This top bar should be as shown at the top of the up rights.
- A second cross bar is compulsory, a third is optional; these must be welded or bolted to the uprights.
- **THE ROLL BAR MUST NOT HAVE ANY REAR SUPPORTS but may have extensions no further forward than the B post.**
- The minimum size for roll bar is 2" (50mm), maximum size 4" (100mm), and minimum thickness 3mm.
- Crossbars must have a 5" (125mm) square end plate fitted. This must be minimum 6mm thick.
- The roll bar cross bars must be straight, or extended forward to the B pillar and bolted through the pillar
- Each upright must have a **minimum** of two bolts on each side to the floor and two each side at the top.
- The maximum size of the base plate is 15" (385mm) x 11" (280mm) and base plates cannot be connected to each other over the tunnel.
- You must tie the seat at shoulder level to the roll cage or B pillar, through the seat frame not headrest, you may fit the 2nd cross bar in support of the seat just below the window aperture or weld a frame on the cage to support the seat at the top.
- **Foam Padding made from an appropriate material to offer protection** must be fitted to the roll cage above the head, to the door pillar at the side of the drivers head and around the steering column.
- The roll bar must not have any rear support or extensions but may have a forward facing extension no further forward than the B pillar
- **Harness eyes only to be used welded/bolted and must be attached to the cage or a 10mm 100x100 flat plate bolted to the floor with suitable washers on the underside behind the drivers seat. It is permitted to use chain to extend the mounting, 8mm minimum and if fusion welded type, be rewelded for strength.**

BODYWORK

Doors

- The Drivers door is only part on the car that can be welded and a piece of box or tube can be welded to the lower window aperture. No other welding is permitted anywhere else on the car apart from the sun roof plate.
- All the other doors must be fastened, you can use strips of metal, and the strips must be no longer than 400mm or 15¾" in length, by 60mm or 2½" in width. Max four bolts can be used to attach each strip and the minimum size of the bolts/studding is 8mm in diameter & the maximum is 12mm diameter. Seat belt webbing can be used instead of Metal strips or the doors can be fixed with 4 x 12mm bolts directly through the Panels.

- The tops of the door frames may also be tied with seat belt webbing, this must be around the pillars and not through the roof, but you can still fit the door strips. Do not weld these other doors.
- One seat belt may be fitted through the bottom of the door and floor in the centre of the front passenger door only
- Repair patches must only be of a maximum 1 patch thickness to the original spec. Previous repair patches may not have new patches put over them.
- Drivers door plate must have a minimum size M16 Bolt to hold it on
- A driver's door plate must be fitted & overlap the door pillars by a minimum of 75mm or 3".
 - NB. No trench plates are permitted.
- The plate must be a minimum of 10mm or 3/8", to a maximum of 19mm or 3/4" in thickness.
- Its depth must be no less than 254mm or 10" & no more than 305mm or 12".
- The plate must be fixed by either four 16mm or 19mm fixings, through the door pillars with large washers on the inside.
- The door plate holes must not be slotted.
- An additional piece of angle iron or box section, not exceeding 76mm or 3" in its width and of any gauge, may be welded horizontally along the length of the door plate. The ends of this horizontal section must have the ends tapered or cut at an angle so as to prevent getting tangled up in rubbing situations. Any bolt fixings must not protrude this section of metal, they must be flush.
- **It is COMPULSORY to fit a steel plate to the driver's floor-pan.** It must be no thicker than 6mm, and must be bolted and/or welded in. This may be modified to rise to the maximum height of the sill of the door side only.
- Digger blade must not be used as a door bar • No welded plates are allowed to hold the door bar on.
- **No welded plates are allowed to hold the door bar on.**

Front & Rear Bumpers

- Original bumpers may remain, but plastic bumpers must be removed.
- The original metal fixing behind the plastic bumper can remain and must be bolted, not welded. If there is no metal piece behind the plastic bumper on the front, then a replacement front bumper may be fabricated. The fabricated front bumper must be a maximum of 75mm x 3mm thick, and may be folded up the side of the chassis rails by a maximum of 3" with a maximum of 2 bolts on each side – no welding. The bolts must go through the chassis, not up the chassis.
- NO replacement bumper is permitted on the back of the car.
- No tow bar must be left on the car.
- Front bumper can also be replaced with a chain
- There must be no tape or seatbelt on the front bumper
- **No aluminium bumpers are allowed**

Front Wings

- The lower part of the wing may be trimmed level to where with the top of where the bumper was.

Bonnet Fixings

- **Bonnet bolts may be used but only towards the rear and MUST NOT go further forward than the front turret. The plates that go with these bolts must be a maximum of 6" square. The Front of the Bonnet must be secured by seatbelt only with 2 bits of seatbelt.**
- **At the rear of the bonnet you must have two triangular corner plates which are a maximum of 12" in length. These can be tack welded or bolted. If tack welded must be to a maximum of 1" (25mm) weld with a 1" (25mm) gap in between.**

Aerofoils, Wings & Spoilers

- Aerofoils / wings or spoilers are NOT permitted.

Grilles

- These must be removed.

Boot / Rear Hatches

- Boots / rear hatches can be **bolted attached** with a maximum of four **bolts fixings**; which can be a maximum of four bolts, or four seatbelts, or two bolts and two seatbelts.

Driver's Floor Plate

- A steel plate fitted to the drivers floor pan is compulsory Floor plates may extend no further back than the front of the seat squab and must remain in the drivers footwell only and must be made of 3mm steel minimum
- It must be no thicker than 6mm and must be bolted in only.
- Floor plates may extend up the side of the transmission tunnel, to the same height as the door sill, and up the bulkhead to within 200mm (8") of the top of the bulkhead, but the plate can only be bolted through the floor and the A-pillar only, not to the sill or bulkhead. You may put two bolts maximum in the gearbox tunnel with a maximum 50mm washer size.
- A 4" (100mm) steel plate no thicker than 6mm bolted through the A pillar to the door plate can be welded or bolted to the floor plate.

Roof Plate

- Roof plates are compulsory. The minimum thickness of flat steel plate is 3mm, and it must be secured by a minimum of 8 bolts or welded. The roof plate must not extend further back than 75mm from the rear of the roll cage uprights.

Oil Filter Guard

- An oil filter guard may be **BOLTED** to the engine block only. This must only be the size of the oil filter otherwise will not be allowed.

ENGINES

- Corsa C 1.2 can run the Corsa B 1.2 ECU and Inlet Manifold with the throttle body and also the Ford Fiesta Mk 6 May also use the Ford Fiesta Mk 5 ECU (Part number XS6E9424CC only) and Inlet with the throttle body as cable.
- The engine and running gear must remain as it was produced in its standard form for that vehicle model. I.e. throttle and injection must be from the original model. I.e. Fiesta to Fiesta and not Focus to Fiesta.
- Any transplants must be model to model ie NOT NISSAN to NISSAN but NISSAN MICRA TO NISSAN MICRA etc.
- The air filter may be removed or replaced.
- Only the 34 ICH Weber carburettor may be used to replace the standard carburettor for the model of car being raced. Jets may be changed but no drilling of any parts.
- No modification to the carburettor allowed.
- If car is originally fitted on injection it must not be replaced with carburettor – it must stay on the original injection.
- Any alteration or removal of engine numbers will deem the engine illegal.
- The standard ECU that was manufactured with the engine must be used. There will be a buyout clause of the ECU and Loom complete for £100. Anyone wishing to purchase another driver's ECU and Loom must do so by approaching the meeting steward and not the driver concerned. The promoter may also purchase this at any time for the above price. ***This must be exercised before the start of the final race of the day for the Junior Rookies. With the money paid to the secretary at the time of the request. The removal must be carried out by the parent/mechanics and witnessed by a committee member and scrutineer. Failure to comply will result in the relevant disciplinary actions being carried out.***
- Rev Limiters **MUST NOT** be tampered with in any way. If a driver is found to have tampered with this they will be immediately loaded from the meeting even if this is found at pre meeting scrutineering. If a driver is found to have tampered with the Distributor, the Promotion has the right to keep hold of this to prevent future use.
- There will be a buyout clause of the engine and gearbox complete for £350. Anyone wishing to purchase another driver's engine and gearbox must do so by approaching the meeting steward and not the driver concerned. The Promoter may also purchase this at any time for the above price. ***This must be exercised before the start of the final race of the day for the Junior Rookies. With the money paid to the secretary at the time of the request. The removal must be carried out by the parent/mechanics and***

witnessed by a committee member and scrutineer. Failure to comply will result in the relevant disciplinary actions being carried out.

GEARBOX

- The Transmission must be kept as produced for the model in its standard form.
- You may not lock the differential or any type of slipper or power lock differential cannot be used even if fitted as standard.

Engine / Gearbox Mounts

- Alloy engine/gearbox mounts can be replaced by fabricated steel versions and welded or bolted to the chassis. The maximum size of the mount is 5 inches where it is attached to the chassis. The mount must not exceed the original size of the standard mount which is being replaced, it is solely for holding the engine in and not for strengthening, and no part of the mount must be in front of the engine. The mount must also bolt to the original bolt holes
- **Any front engine mounting must not go below the block in order to protect the sump.**
- Flywheels and Gearboxes may be used from model of car but must be in standard form.
- **Only one additional solid engine mount may be fitted to the face of the engine block protruding 50mm forwards and nothing backwards from the face of the engine.**
- **Engine mounts that are already fitted and protrude 75mm forwards from 2024 will need to have been replaced as will no longer pass.**
- **We recommend when striping the cars to replace at that point. All engine mounts purchased this year will need to be 50mm**

WHEELS, TYRES & SUSPENSION

- **All four wheels must be of the same diameter.**
- All wheel fixings must be in place.
- All wheel weights & hub caps must be removed
- Any standard road wheel steel or alloy can be used up to a width of 6".
- No modifications to hubs or rims
- No Weller rims permitted.
- Only conventional tyres may be used.
- Tyres must read a minimum of 60 on a durometer at any time.
- Tyre Gaiters are permitted.
- **“Run flat” tyres, 1B rated ‘Track-day’ tyres, Rally tyres, competition type, cut tyres, Town and Country, Mud & Snow Type or Kingpin Alpine Series tyres are NOT allowed**
- **The tyres will need to be the same size / profile / width on the same axle**

<p>AVON</p> <ul style="list-style-type: none"> • ACB 10 Sport • CR6ZZ (Including Sport) • Turbospeed CR28 Sport • CR500 • ZZR <p>BRIDGESTONE</p> <ul style="list-style-type: none"> • Potenza S007 RFT <p>CONTINENTAL</p> <ul style="list-style-type: none"> • ContiForce Contact <p>DMACK</p> <ul style="list-style-type: none"> • Trackday <p>DUNLOP</p> <ul style="list-style-type: none"> • Formula R D83J • Formula R D84J 	<p>GOODYEAR</p> <ul style="list-style-type: none"> • EAGLE F1 <p>HANKOOK</p> <ul style="list-style-type: none"> • Z209 • Z210 <p>KUMHO</p> <ul style="list-style-type: none"> • Ecsta V700 (inc V78) • Ecsta V70A • Ecsta TW01 • Ecsta TW02 • Ecsta C03 <p>MARANGONI</p> <ul style="list-style-type: none"> • Zeta Linea Sport <p>MAXXIS</p> <ul style="list-style-type: none"> • Maz1 Drift 	<p>NANGKANG</p> <ul style="list-style-type: none"> • NS-2R <p>PIRELLI</p> <ul style="list-style-type: none"> • P Zero Trofeo • P Zero C • CA67 • CF67 • P Zero Corsa • P7 Corsa Classic • P Zeri Torfeo R12 <p>SILVERSTONE</p> <ul style="list-style-type: none"> • FTZ Sport RR • FTZ Wet Tyre • S575 • S585 <p>TOYO</p>
--	---	---

<ul style="list-style-type: none"> • Formula R D93J • Direzza 02G • Direzza 03G • CR 311 • Sport Maxx Race • SP Sport R7 <p>FEDERAL</p> <ul style="list-style-type: none"> • 595 EVO • 595 RSR • FZ 201 	<p>MAXSPORT</p> <ul style="list-style-type: none"> • RB4 Intermediate • RB5 <p>MICHELIN</p> <ul style="list-style-type: none"> • Pilot Sport Cup • Pilot Sport Cup 2 • TB 15 • TB 15 (f & r) 	<ul style="list-style-type: none"> • R888 • R1-R <p>YOKOHAMA</p> <ul style="list-style-type: none"> • All Tyres
---	--	---

PLEASE NOTE : All tyres listed in the table above are NOT allowed.

Warton Stock Car Club reserves the right to ban any tyre make or type which gives an unfair advantage. Decisions on which tyres are permitted will be at Scrutineer's discretion.

- Suspension. All suspension must remain standard to the car which is being raced. No re-valving oil on shock absorbers and no changing or lowering of the springs is permitted. Camber is not permitted on any wheel on a fresh car. Camber on race damaged cars will be down to scrutineers' discretion as to whether or not they feel this will provide an unfair advantage.
- **Micra or similar cars may use a strap connecting the two wishbones, but this may not be connected to any other part of the car or the engine. This strap must be a maximum of 2"x 2" (50mm x 50mm), and can only be used on cars with no subframe.**
- Anti Roll Bar must be fitted as standard or totally disconnected at links.
- **You may strengthen the bottom arm on the passenger side only. The arm may not be modified in any way and may only be strengthened. Please note the scrutineers decision is final and anything considered to be OTT by officials will not be allowed. This rule came into place from the 1 April 2024**
- **The Rear Springs must be tied in with seatbelts around the bottom only.**

EXHAUSTS

- An exhaust silencer must be fitted and reduce noise. It does not have to be the original manufacturers system.
- No competition type systems are allowed
- **No 'Cherry Bomb' type silencers are permitted**
- Extra fittings are permitted.
- **Ineffective or systems that become insecure while racing will require you to pull off the track. You will be shown a black flag for mechanical failure and you will be excluded from the results – Failure to obey this flag may result in additional penalties.**
- The original manifold and down pipes must be used but if the car is fitted with a catalytic converter, the catalytic converter may be removed inside. If it is a car where the catalytic converter is on the exhaust you may cut that part out and replace it with tube that slides just over the original exhaust. Silencers maybe changed but no cherry bomb type are permitted. Any car that seems to be too noisy will not be permitted to race. This is at the scrutineer and Steward of the Meetings discretion.
- The exhaust must not finish before the rollcage.

COOLING SYSTEM

- Radiators are free & may be moved to any position in the engine bay.
- Steam tanks may be used and may be L-shaped but must not have any part forward of the centre of the strut or front wheel on the passenger side. They may go across the bulk head behind the engine but that part must be rectangular only and not extend at all down towards the driver's side strut.
- Electric cooling fans may be wired through a separate switch.
- **Any cooling pipes which pass in front of the engine must be flexible and not made of metal**

BRAKES

- The *standard* manufacturers system must be used & work on all 4 wheels.
- The handbrake must also be operational.

FUEL SYSTEM

- The maximum capacity of the fuel tank must not exceed 9 litres.
- **No converted fire extinguishers are allowed.**
- **The fuel tank must be fitted ONTO the H frame and NOT on the H Frame floor plates, i.e. NOT on the car floor itself. It should be kept away from the sides of the car in case of side impact.**
- Fuel caps must be of a metal screw type, no push fit types are allowed
- The fuel outlet must be from the top of the tank.
- The tank must have a positive means of fixing.
- A breather pipe must be fitted which should incorporate a one-way valve, with the pipe terminating below the tank so as to prevent spillage if inverted.
- All fuel lines must be of good quality rubber or be metal covered, no rigid metal piping is allowed.
- Only roadside fuel can be used, Petrol or Diesel. No additives are allowed.
- ~~If an electric pump is fitted, a cut-off switch must be in close proximity of the driver.~~ **A fuel shut off tap must be fitted between the fuel tank and the fuel pump to stop fuel supply to the pump when turned off and within reach of the driver and the marshal from the outside.**
- Multi point injection can be used with a return back to the tank or a t-piece fitted in the fuel line between the fuel tank and the fuel pump but the electrical isolation switch (cut off switch) must be fitted in the N/S/R window area of the B post, for easy access of Safety Marshalls.
- You may also remove the Single or Multi-point injection system and replace it with a conventional carburettor if it's available from the manufacturers range. If you have doubts about the legality of the change, please contact a scrutineer.
- With carburettor fuelled cars, a manual shut-off tap must be fitted within reach of the driver when strapped in the car, but with fuel injected cars, the fuel flow must be controlled by the pump cut off switch. Immersed fuel pumps are permitted.
- **Any inline fuel pumps must have a fuel tap fitted**

BATTERIES & THE ELECTRICAL SYSTEM

- The Battery must be bolted and clamped in position. Ratchets may be used as a secondary
- If battery is mounted on the floor it must be secured in a box, the maximum size is to be 18" x 12" or equivalent.
- The batteries must be a minimum of 152mm or 6" away from the fuel tank.
- No seatbelt straps must interfere with or come into contact with the battery.
- A battery master switch must be fitted in the rear left-hand window and clearly marked "ON-OFF" or have an electrical danger decal. The cut-off switch must break the earth connection lead. **Battery cut off switch must be fitted to passengers' side upright in the forward facing position at window aperture height within easy reach for a marshall and the switch must be wired to the earth side of the battery**
- A self-starter motor must be fitted & working at all times.

MIRRORS

- The Interior mirror may be fitted.
- Maximum mirror size is 152 x 100mm or 6"x4" and if glass, it must be covered in a clear plastic film to stop the glass fragmenting.

SUN VISOR

- A Sun visor 165mm or 6" in depth may be fitted with your name upon it. **If it is curved the deepest point can be no more than 150mm**

FIN PLATES

- Fin plates must be fitted above the roof line but they should not be larger than 305mm or 12” by 559mm or 22” wide.
- Fin plate numbers must be clear and legible, black on white or white on black is highly recommended. ***If the lap scorers can not read them you won't be scored during a race.***

RACEIVER

- All drivers **MUST** use an official Raceiver. Any driver whose Raceiver is not working when forming the grid prior to a race will not be allowed to race, unless it can be repaired before the race start. It is strongly recommended that you carry a spare battery either in your overall pocket or taped inside your car.

TRANSPONDERS

- All drivers **MUST** use a Warton Stock Car Club registered transponder. These must be fitted to the H frame behind the drivers seat facing outwards towards the armco.

SPECIFICATIONS & RULES CHANGES

The Promotion may at any time make amendments to the Specifications for the following reasons:

- In the interests of Safety
- Reduce costs for the driver
- In areas that are detrimental to the future of the formula
- If an unnecessary advantage has been deemed to have been gained

ANY CONTRAVENTION OF THE ABOVE RULES CAN RESULT IN THE DRIVER RECEIVING DISCIPLINARY ACTION AND/OR SUSPENSION.

THE ABOVE RULES WILL BE AMENDED, OMITTED OR ADDED TO AT THE DISCRETION OF THE CLUB COMMITTEE. THE LICENCES ISSUED BY THE CLUB ARE FOR WARTON ONLY, THEY ARE NOT TRANSFERABLE.

IF THE RULES DO NOT SPECIFY THAT YOU CAN, THEN TAKE IT THAT YOU CAN'T

Updated 16th April 2026

These rules are valid with immediate effect.