

Warton Stock Car Club

Junior Rookie Rules

This formula is designed to encourage new young drivers to Warton Stock Car Club, to enjoy the atmosphere and thrills of driving on an oval, without the substantial financial investment.

The object of the racing is to complete the specified number of laps in the shortest time. You may push a car from behind, or spin a car to the infield but there is no following in (you must not be on the back or side of a car as it hits the fence whether from the rear, front or side as this will be deemed forcible fencing and carry penalties or a ban which could be for life). **Deliberate hitting of stationary cars is not permitted.**

Driver's must be between the ages of 11 and 15 – the earliest date upon which someone can race is on their 11th birthday. The latest date is the day before their 16th birthday. All licence applications will be reviewed by the club and it must be understood that applications may be refused at the club's discretion. Falsifying documents or providing misleading information about age in order to get round the rules carries a lengthy ban from all formulas. All drivers have to complete a competence assessment prior to racing.

Day licences are permitted for one meeting ONLY. Once you have had a day licence you must purchase a full membership if you wish to race again. To run on a day licence you will need to hire a Racever.

There is a list of eligible cars which is below, if you have a car not listed below please contact a scrutineer to check if it is eligible. The car must be a right - hand 2 wheel drive saloon, hatchback or estate car with a steel body with an engine size not exceeding 1300cc, with either carburettors or Multi Point Injection or Diesel.

Engine limit – 1300cc – some models listed below were not made under 1300cc in which case an engine transplant under 1300cc must be used.

Austin - A30 / A35 / A40 (Farina only - NOT Somerset or Cambridge) / 1100 / 1300 / Allegro / Metro

Chevrolet – Matiz

Citroen - 2CV / Dyane / AX / Saxo / Visa / C1

Daewoo - Matiz

Daihatsu – Charade / Move

Datsun - 100A (Cherry)

Fiat - Panda / Punto / Uno / 126 / 127 / Cinquecento / Tipo / Seicento

Ford - Fiesta / KA / Popular 100E / Anglia

Hillman - Imp

Honda - Civic (1st generation 1972 - 1979 only) / Logo

Hyundai – i10 / Amica

Kia – Pride / Picanto

Lada – Samara

Lancia - Fulvia

Mini (Not BMW Mini)

Mazda – 121 / 323 (3rd generation 1977 - 1980 and 4th generation 1980 - 1984 hatchbacks only – not booted versions or estates) / Demio

Morris - 1100 / 1300 / Minor

Nissan – Micra (K10-K12) / Pixo

Perodua - Kenari

Peugeot - 104 / 106 / 107 / 205 / 206

Proton – Satria / Compact

Renault - 4 / 5 / 6 / 10 / Clio / Modus / Twingo

Riley - Elf

Rover - 100 (Metro shape - not p4!)

Seat – Ibiza (mk.1 1984 - 1993 & mk.2 1993 - 2002) / Arosa

Skoda – Favorit (saloon only – NOT estate)

Smart Car

Subaru - Vivio

Suzuki – Swift / Wagon R / Baleno (3 door hatchback ONLY, NOT booted version or estate)

Talbot - Samba

Toyota – Starlet / Aygo / Yaris

Vauxhall - Nova / Corsa (excluding 'D') / HA Viva / Chevette

Volkswagen - Polo / Beetle / Fox / Lupo

Wolseley - Hornet

Yugo

INITIAL PREPARATIONS

- Remove all exterior mouldings, screen glass, lamps and handles.
- Remove all **airbags and charges (if fitted)**, interior trim, the dash & passenger seating.
- Remove the fuel tank, spare wheel carrier & tow bar if fitted.
- Remove rear spoilers and side skirts even if factory fitted.
- Remove all obsolete wiring and interior debris from the car.
- It is compulsory to pad steering columns, B pillar and roll cage with high density foam – it is NOT permissible to use non-high density padding such as clothing, towels etc.
- For Safety reasons, it is compulsory to fully tape over the steering wheel to avoid possible wrist injury. This can be with tape or a substantial perspex disc.

DRIVERS SEAT WITH HEAD RESTRAINT

You must have a Driving Seat with a head restraint and this may be of a competition type. The seat should occupy its original position where possible and be suitably supported at shoulder height and on both of the sides and back, with a suitable framework or seat stiffeners.

SAFETY HARNESS

The lap belt/straps and crotch straps should not pass over the sides of the seat, but through it, in order to wrap and hold the pelvic region over the greatest possible surface. A minimum of a four point buckle fixing must be used with a minimum of 3 floor fixings. A secure part of the floor or cage (including the seat bar), are recommended anchor points. All seatbelt connection points must be visible and no belts pass through any firewall.

The lap belt crossing should be below the anterior-superior iliac spines (bony part of the hip). Under no circumstances should it be worn over the region of the abdomen.

Lap belt/straps must terminate vertically downwards, and not forwards or rearwards of the hip joint.

Lap straps should terminate symmetrically about the wearer on either side of the seat, about 20" (500mm) apart. The distance between the seating surface and the anchorage point should be kept to a minimum to prevent submarining. The location of the crotch strap mounting should be to the rear of the driver.

All belts must connect to the quick release buckle. The abdominal strap fixing point must be on the chassis, roll cage, or floor (for vehicles with no chassis), either side of the driver.

The shoulder straps must be supported at shoulder height. NASCAR type buckles must be fitted with lever on the **right** side of the driver. It is advisable to fit a secondary means of detent to prevent overall sleeves accidentally unhooking the buckle during racing. A small section of tube grip **elasticated** bandage, slid over the hooked buckle, serves the purpose.

Special attention must be paid to the condition of seat belt fixings once fitted. Information is available, from your Promotion, on the correct procedure to follow when fitting seat belts. *Remember - your life depends on them, and belts, once involved in a severe accident, should be discarded and replaced.*

Over the years, we have had many unnecessary injuries due to badly fitted seats. They frequently occur in Non-contact Formulas, when perhaps a driver believes it is more unlikely that he will be involved in a serious crash, and he also believes that, if he is involved in a collision, the impact on his car will be from the front. However, this is often not the case. It is therefore, imperative that you ensure your seat is really well supported, especially where the shoulder straps go through. You must also ensure that your seat cannot move sideways

The safety of your seat will be judged by the Scrutineers and you will only be permitted to race when they are satisfied that you will be as safe as possible in any event.

WINDOW NET

A race manufacture window net in the driver's door window is **compulsory**. This should be fitted so it can easily and quickly be opened by hand if necessary from the outside of the car by an official in an emergency.

VIOLATIONS

- When referring to the engine, gearbox, final drive, mechanical or construction Rules & Regulations, the principle will always be: Unless permission is specifically granted to make modifications (or any variation) nothing may be done to alter or change the Standard Parts in any way.
- It is the responsibility of the Driver to prove to the Promotion that the part is legal, by way of written proof of where the part originated. This must be undertaken within 7 days, otherwise the item in question will be deemed illegal, resulting in immediate suspension from racing and referral for disciplinary action.
- Presentation of a Vehicle for Scrutineering is a declaration by the entrant that the vehicle is eligible for that event.
- Car engines and fuel will be checked on a random basis. Violations or refusal to allow an engine check will result in an immediate suspension of all racing facilities.
- All Car and Engine Specifications will be taken from either the manufacturers Technical Specifications or the Technical Service Data books as published by Glass's Guide.
- Should a discrepancy occur between the Specifications then the Promotion will exercise it's judgement, and that decision will be final.
- Clarification on any one item may be sought from the Promoter.
- Each driver is permitted one car per meeting and each car is permitted one driver per meeting.

GENERAL RULES OF RACING

- Drivers apprehensive about contact can display on the rear of the car a black or white X, to signify to other drivers that they must not make contact with your car during racing.
- The Clerk of the Course has at his discretion the right to remove the cross from you, when he thinks you are confident to race with the others.
- You must line up in reverse points order, with the superstar/reds at the rear of the grid, with blue, yellow and white in front.
- Race winners will start at the back of their respective roof grade for the following race.

ROLL BAR

- Roll cages may be adjustable (height and width), however the use of screw adjusters i.e. acrow style are not permitted.
- The roll cage must be fitted upright or dog-legged, but not leaning back or forward.
- **It is compulsory to pad roll cages, including the B pillar and steering columns must also be padded with high density foam.**

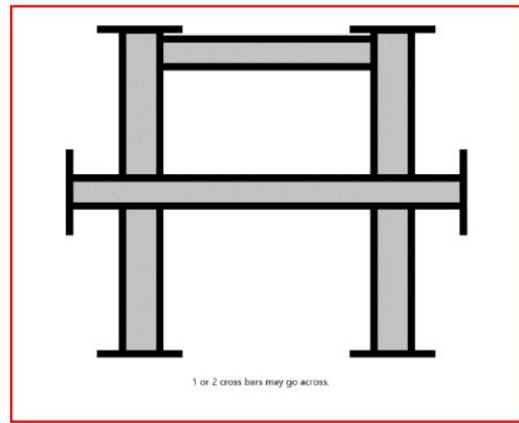
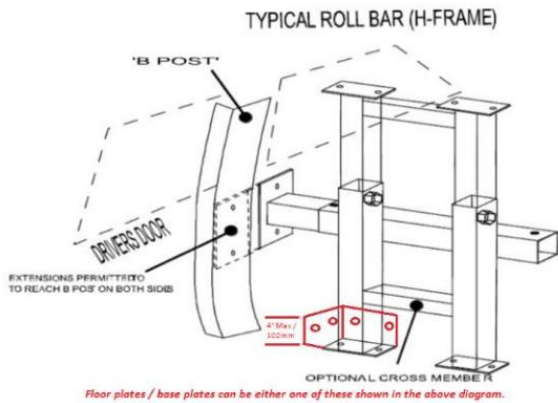

These two diagrams are a guideline to how the frame should be constructed but gusseting or triangulation is accepted.

- The hoop must be one piece or two uprights and one top bar of a welded construction. This top bar should be as shown at the top of the up rights.
- A second cross bar is compulsory, a third is optional; these must be welded or bolted to the uprights.
- THE ROLL BAR MUST NOT HAVE ANY REAR SUPPORTS but may have extensions no further forward than the B post (see diagram below). If used, it is recommended that this is bolted through the B post.
- It is highly recommended that the frame is bolted through both sides of the car.
- The minimum size for roll bar is 2" (50mm), maximum size 4" (100mm), and minimum thickness 3mm.
- Crossbars must have a 5" (125mm) square end plate fitted. This must be minimum 6mm thick.
- The roll bar cross bars must be straight, or extended forward to the B pillar and bolted through the pillar
- Each upright must have a **minimum** of two bolts on each side to the floor and **two** each side at the top.
- You must tie the seat at shoulder level to the roll cage or B pillar, through the seat frame not headrest, you may fit the 2nd cross bar in support of the seat just below the window aperture or weld a frame on the cage to support the seat at the top.
- Foam padding must be fitted to the roll cage above the head, to the door pillar at the side of the drivers head and around the steering column.

BODYWORK

Doors

- The Drivers door is only part on the car that can be welded and a piece of box or tube can be welded to the lower window aperture. No other welding is permitted anywhere else on the car apart from the sun roof plate.
- All the other doors must be fastened, you can use strips of metal, and the strips must be no longer than 400mm or 15¾" in length, by 60mm or 2½" in width. Max four bolts can be used to attach each strip and the minimum size of the bolts/studding is 8mm in diameter & the maximum is 12mm diameter. Seat belt webbing can be used instead of Metal strips or the doors can be fixed with 4 x 12mm bolts directly through the Panels.
- The tops of the door frames may also be tied with seat belt webbing, but you can still fit the door strips. Do not weld the other doors.
- **One seat belt may be fitted through the bottom of the door and floor in the centre of the front passenger door only**
- A driver's door plate must be fitted & overlap the door pillars by a minimum of 3".
- *NB. No trench plates are permitted.*
- The plate must be a minimum of 10mm or 3/8", to a maximum of 19mm or 3/4" in thickness.
- Its depth must be no less then 254mm or 10" & no more than 305mm or 12".
- The plate must be fixed by either four 19mm fixings or six 12mm fixings, through the door pillars with large washers on the inside.
- The door plate holes must not be slotted.
- An additional piece of angle iron or box section, not exceeding 76mm or 3" in its width and of any gauge, may be welded horizontally along the length of the door plate. The ends of this horizontal section must have the

ends tapered or cut at an angle so as to prevent getting tangled up in rubbing situations. Any bolt fixings must not protrude this section of metal, they must be flush.

- **It is COMPULSORY to fit a steel plate to the driver's floor-pan.** It must be no thicker than 6mm, and must be bolted and/or welded in. This may be modified to rise to the maximum height of the sill of the door side only.

Front & Rear Bumpers

- Original bumpers may remain, but plastic bumpers must be removed.
- The original metal fixing behind the plastic bumper can remain and must be bolted, not welded. If there is no metal piece behind the plastic bumper on the front, then a replacement front bumper may be fabricated. The fabricated front bumper must be a maximum of 75mm x 3mm thick, and may be folded up the side of the chassis rails by a maximum of 3" with a maximum of 2 bolts on each side – no welding. The bolts must go through the chassis, not up the chassis.
- NO replacement bumper is permitted on the back of the car.
- No tow bar must be left on the car.
- **Front bumper can also be replaced with a chain**
- **There must be no tape or seatbelt on the front bumper**

Front Wings

- The lower part of the wing may be trimmed level to where with the top of where the bumper was.

Bonnet Fixings

- Bonnet bolts may be used but only towards the rear and **MUST NOT** go further forward further than the front turrett. The plates must be a maximum of 6" square. The Front of the Bonnet must be secured by seatbelt only with a maximum of 2 ties.
- Triangular corner plates or straps may be used to secure the rear of the bonnet by bolting or welding (1/8"thick). Plates or straps must be placed no further than 12" across or down from the back edge and side of the bonnet. In this case you may only use two seatbelt fixings at the front.

Sun Roofs

- **Roof plates are compulsory. The minimum thickness of flat steel plate is 3mm, and it must be secured by a minimum of 8 bolts or welded. The roof plate must not extend further back than 75mm from the rear of the roll cage uprights.**

Aerofoils, Wings & Spoilers

- Aerofoils / wings or spoilers are NOT permitted.

Grilles

- These must be removed.

Boot / Rear Hatches

- Boots / rear hatches can be bolted with a maximum of four bolts.

ENGINES

- The engine must remain as it was produced in its standard form for that vehicle model
- Any transplants must be model to model ie NOT NISSAN to NISSAN but NISSAN MICRA TO NISSAN MICRA etc.
- The air filter may be removed or replaced.
- Only the 34 ICH Weber carburettor may be used to replace the standard carburettor for the model of car being raced.
- No modification to the carburettor allowed.
- Multi point injection can be used, but you may also remove the injection system and replace it with the previous carburettor set up or Diesel.
- Any alteration or removal of engine numbers will deem the engine illegal.

- The standard ECU that was manufactured with the engine must be used. *There will be a buyout clause of the ECU and Loom complete for £100. Anyone wishing to purchase another driver's ECU and Loom must do so by approaching the meeting steward and not the driver concerned.*
- **A dizzy guard is optional. This must be bolted to the engine ONLY by no more than 2 fixings and must measure NO MORE than 9" x 9" and maximum thickness of 6mm. No bracing allowed.**
- **A sump guard is optional. This must be bolted to the engine and not welded.**
- **Rev Limiters MUST NOT be tampered with in any way**
- *There will be a buyout clause of the engine and gearbox complete for £350. Anyone wishing to purchase another driver's engine and gearbox must do so by approaching a committee member and NOT the driver concerned*

GEARBOX

- The Transmission must be kept as produced for the model in its standard form.
- You may not lock the differential or any type of slipper or power lock differential cannot be used even if fitted as standard.

Engine / Gearbox Mounts

- Alloy engine/gearbox mounts can be replaced by fabricated steel versions and welded or bolted to the chassis. The maximum size of the mount is 5 inches where it is attached to the chassis. The mount must not exceed the original size of the standard mount which is being replaced, it is solely for holding the engine in and not for strengthening, and no part of the mount must be in front of the engine.
- Any front engine mounting must not go below the block in order to protect the sump.
- Flywheels and Gearboxes may be used from model of car but must be in standard form.

WHEELS, TYRES & SUSPENSION

- All four wheels must be of the same diameter.
- All wheel fixings must be in place.
- All wheel weights & hub caps must be removed
- Any standard road wheel steel or alloy can be used up to a width of 6".
- **No modifications to hubs or rims**
- No Weller rims permitted.
- Only conventional tyres may be used.
- Tyres must read a minimum of 60 on a durometer at any time.
- Tyre Gaiters are permitted.
- Tyres must be a minimum of 60 Series from 1 June 2019
- "Run flat" tyres, 1B rated 'Track-day' tyres, Rally tyres, competition type, cut tyres, Town and Country, Mud & Snow Type or Kingpin Alpine Series tyres are NOT allowed.

<p>AVON</p> <ul style="list-style-type: none"> • ACB 10 Sport • CR6ZZ (Including Sport) • Turbospeed CR28 Sport • CR500 • ZZR <p>BRIDGESTONE</p> <ul style="list-style-type: none"> • Potenza S007 RFT <p>CONTINENTAL</p> <ul style="list-style-type: none"> • ContiForce Contact <p>DMACK</p> <ul style="list-style-type: none"> • Trackday <p>DUNLOP</p> <ul style="list-style-type: none"> • Formula R D83J 	<p>GOODYEAR</p> <ul style="list-style-type: none"> • EAGLE F1 <p>HANKOOK</p> <ul style="list-style-type: none"> • Z209 • Z210 <p>KUMHO</p> <ul style="list-style-type: none"> • Ecsta V700 (inc V78) • Ecsta V70A • Ecsta TW01 • Ecsta TW02 • Ecsta C03 <p>MARANGONI</p> <ul style="list-style-type: none"> • Zeta Linea Sport <p>MAXXIS</p>	<p>NANGKANG</p> <ul style="list-style-type: none"> • NS-2R <p>PIRELLI</p> <ul style="list-style-type: none"> • P Zero Trofeo • P Zero C • CA67 • CF67 • P Zero Corsa • P7 Corsa Classic • P Zeri Torfeo R12 <p>SILVERSTONE</p> <ul style="list-style-type: none"> • FTZ Sport RR • FTZ Wet Tyre • S575 • S585
--	--	--

<ul style="list-style-type: none"> • Formula R D84J • Formula R D93J • Direzza 02G • Direzza 03G • CR 311 • Sport Maxx Race • SP Sport R7 <p>FEDERAL</p> <ul style="list-style-type: none"> • 595 EVO • 595 RSR • FZ 201 	<ul style="list-style-type: none"> • Maz1 Drift <p>MAXSPORT</p> <ul style="list-style-type: none"> • RB4 Intermediate • RB5 <p>MICHELIN</p> <ul style="list-style-type: none"> • Pilot Sport Cup • Pilot Sport Cup 2 • TB 15 • TB 15 (f & r) 	<p>TOYO</p> <ul style="list-style-type: none"> • R888 • R1-R <p>YOKOHAMA</p> <ul style="list-style-type: none"> • All Tyres
---	---	--

PLEASE NOTE : All tyres listed in the table above are NOT allowed.

Warton Stock Car Club reserves the right to ban any tyre make or type which gives an unfair advantage. Decisions on which tyres are permitted will be at Scrutineer's discretion.

- Suspension. All suspension must remain standard to the car which is being raced. No re-valving or oil on shock absorbers and no changing or lowering of the springs is permitted. Camber is not permitted on any wheel on a fresh car. Camber on race damaged cars will be down to scrutineers' discretion as to whether or not they feel this will provide an unfair advantage.
- Micra or similar cars may use a strap connecting the two wishbones, but this may not be connected to any other part of the car or the engine. This strap must be a maximum of 2"x 2" (50mm x 50mm), and can only be used on cars with no subframe.
- Anti Roll Bar must be fitted as standard or totally disconnected at links.

EXHAUSTS

- An exhaust silencer must be fitted and reduce noise. It does not have to be the original manufacturers system.
- No competition type systems are allowed
- No 'Cherry Bomb' type silencers are permitted
- Extra fittings are permitted.
- The original down pipes must be used including catalytic converter (if fitted) but silencers maybe changed but no cherry bomb type are permitted. Any car that seems to be too noisy will not be permitted to race. This is at the scrutineer and Clerk of the Course discretion.
- **The exhaust must not finish before the rollcage.**

COOLING SYSTEM

- Radiators are free & may be moved to any position in the engine bay.
- Steam tanks may be used and may be L-shaped but must not have any part forward of the centre of the strut or front wheel on the passenger side. They may go across the bulk head behind the engine but that part must be rectangular only and not extend at all down towards the driver's side strut.
- Electric cooling fans may be wired through a separate switch.

BRAKES

- The standard manufacturers system must be used & work on all 4 wheels.
- The handbrake must also be operational.

FUEL SYSTEM

- The maximum capacity of the fuel tank must not exceed 9 litres.
- No converted fire extinguishers are allowed.

- The fuel tank must be fitted ONTO the H frame and NOT on the H Frame floor plates, i.e. NOT on the car floor itself. It should be kept away from the sides of the car in case of side impact.
- Fuel caps must be of a metal screw type, no push fit types are allowed
- The fuel outlet must be from the top of the tank.
- The tank must have a positive means of fixing.
- A breather pipe must be fitted which should incorporate a one-way valve, with the pipe terminating below the tank so as to prevent spillage if inverted.
- All fuel lines must be of good quality rubber or be metal covered, no rigid metal piping is allowed.
- Only roadside fuel can be used, Petrol or Diesel. No additives are allowed.
- If an electric pump is fitted, a cut-off switch must be in close proximity of the driver.
- Multi point injection can be used with a return back to the tank or a t-piece fitted in the fuel line between the fuel tank and the fuel pump but the electrical isolation switch (cut off switch) must be fitted in the N/S/R window area of the B post, for easy access of Safety Marshalls.
- You may also remove the Single or Multi-point injection system and replace it with a conventional carburettor if it's available from the manufacturers range. If you have doubts about the legality of the change, please contact a scrutineer.
- With carburettor fuelled cars, a manual shut-off tap must be fitted within reach of the driver when strapped in the car, but with fuel injected cars, the fuel flow must be controlled by the pump cut off switch. Immersed fuel pumps are permitted.

BATTERIES & THE ELECTRICAL SYSTEM

- The Battery must be securely fixed & covered with a rot proof material, if it is not of the sealed cell type.
- If battery is mounted on the floor it must be secured in a box, the maximum size is to be 18" x 12" or equivalent.
- The batteries must be a minimum of 152mm or 6" away from the fuel tank.
- No seatbelt straps must interfere with or come into contact with the battery.
- A battery master switch must be fitted in the rear left-hand window and clearly marked "ON-OFF" or have an electrical danger decal. The cut-off switch must break the earth connection lead.
- A self-starter motor must be fitted & working at all times.

MIRRORS

- The Interior mirror may be fitted.
- Maximum mirror size is 152 x 100mm or 6"x4" and if glass, it must be covered in a clear plastic film to stop the glass fragmenting.

SUN VISOR & FIN PLATES

- A Sun visor 165mm or 6" in depth may be fitted with your name upon it.
- Fin plates must be fitted above the roof line and bolted securely to the car.
- No large objects to be used as fins.
- Fin plate numbers must be clear and legible, black on white or white on black is highly recommended. ***If the lap scorers can not read them you won't be scored during a race.***

RACEIVER

All drivers MUST use an official Raceiver. Any driver whose Raceiver is not working when forming the grid prior to a race will not be allowed to race, unless it can be repaired before the race start. It is strongly recommended that you carry a spare battery either in your overall pocket or taped inside your car.

SPECIFICATIONS & RULES CHANGES

The Promotion may at any time make amendments to the Specifications for the following reasons:

- In the interests of Safety
- Reduce costs for the driver

- In areas that are detrimental to the future of the formula
- If an unnecessary advantage has been deemed to have been gained

ANY CONTRAVENTION OF THE ABOVE RULES CAN RESULT IN THE DRIVER RECEIVING DISCIPLINARY ACTION AND/OR SUSPENSION.

THE ABOVE RULES WILL BE AMENDED, OMITTED OR ADDED TO AT THE DISCRETION OF THE CLUB COMMITTEE. THE LICENCES ISSUED BY THE CLUB ARE FOR WARTON ONLY, THEY ARE NOT TRANSFERABLE.

IF THE RULES DO NOT SPECIFY THAT YOU CAN, THEN TAKE IT THAT YOU CAN'T

Updated 13th March 2022

These rules are valid with immediate effect.